



XC-95F

XC-95F Specifications

Description		US Units	Metric Units
Max. drilling diameter	Without casing	126"	3200mm
	With casing	110.3"	2800mm
Max. drilling depth		183'	56m
Standard drilling depth XK400/470/4/40		131'	40m
Engine	Model	CUMMINS X12	
	Rated power	430hp	321kW
	Emission certification	EU stage V, EPA T4F	
Rotary Drive	Max. torque	236,000 ft lbs	320 kN·m
	Rotary speed	5.5~21r/min	
	Spin-off	90±5r/min	
Crowd Winch	Max. crowd force	36 T	330kN
	Max. Lifting force	38 T	350kN
	Stroke	53.8ft	16.4m
Main Winch	Max lifting force of the first layer	31 T	280kN
	Max cable speed	246ft/min	75m/min
Auxiliary Winch	Max lifting force of the first layer	13 T	120kN
	Max cable speed	213ft/min	65m/min
Mast Inclination	Forward/lateral	5°/3°	

XC-95F Specifications

Undercarrige	Max. Travel Speed	4921.5ft/h	1.5km/h
	Max Traction Force	59 T	540 kN
	Max Gradient	35%	
	Track shoe width	31.5"	800mm
	Overall width (retracted~extended)	138~189"	3500~4800mm
	Overall length	242"	6150 mm
Working Dimension	Working condition	394 × 189 × 998"	10005 × 4800 × 25344 mm
	Weight (drilling tool excluded)	228,600 Lbs.	103.7 t
Transport Dimension	Transport condition	631 × 137.9 × 165.5"	16037 × 3500 × 4202 mm
	Disassembled rig	120,150 Lbs.	54.5t
	Mast I	23,800 Lbs	10.8t
	Mast II	3,530 Lbs	1.6t
	Mast III	9,480 Lbs	4.3t
	Inclination cylinders*2	7,050 Lbs	3.2t
	Rotary head	22,050 Lbs	10t
	Counterweight	19,840 Lbs	9t
	Kelly bar & Kelly guide	24,700 Lbs	11.2t

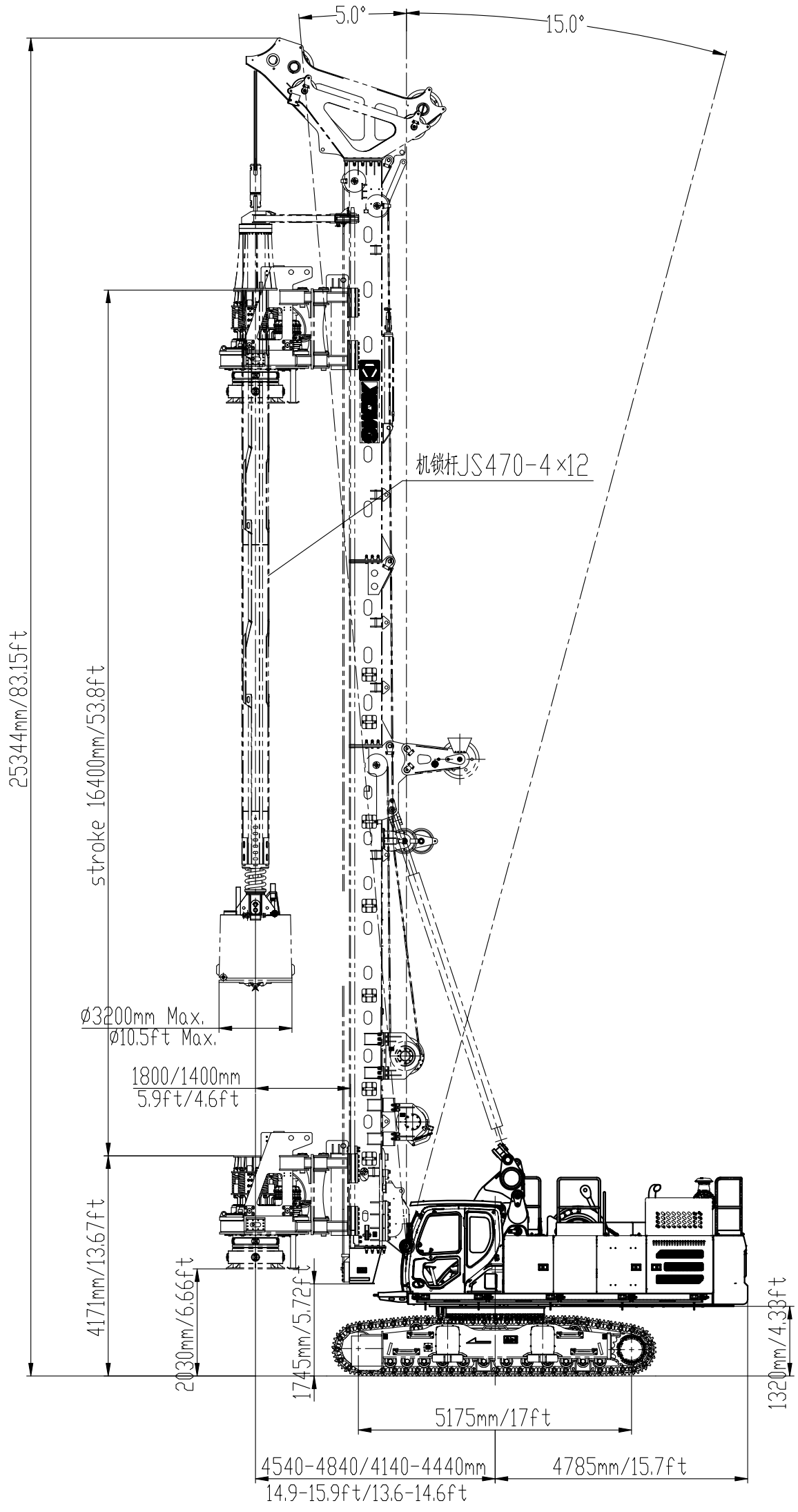

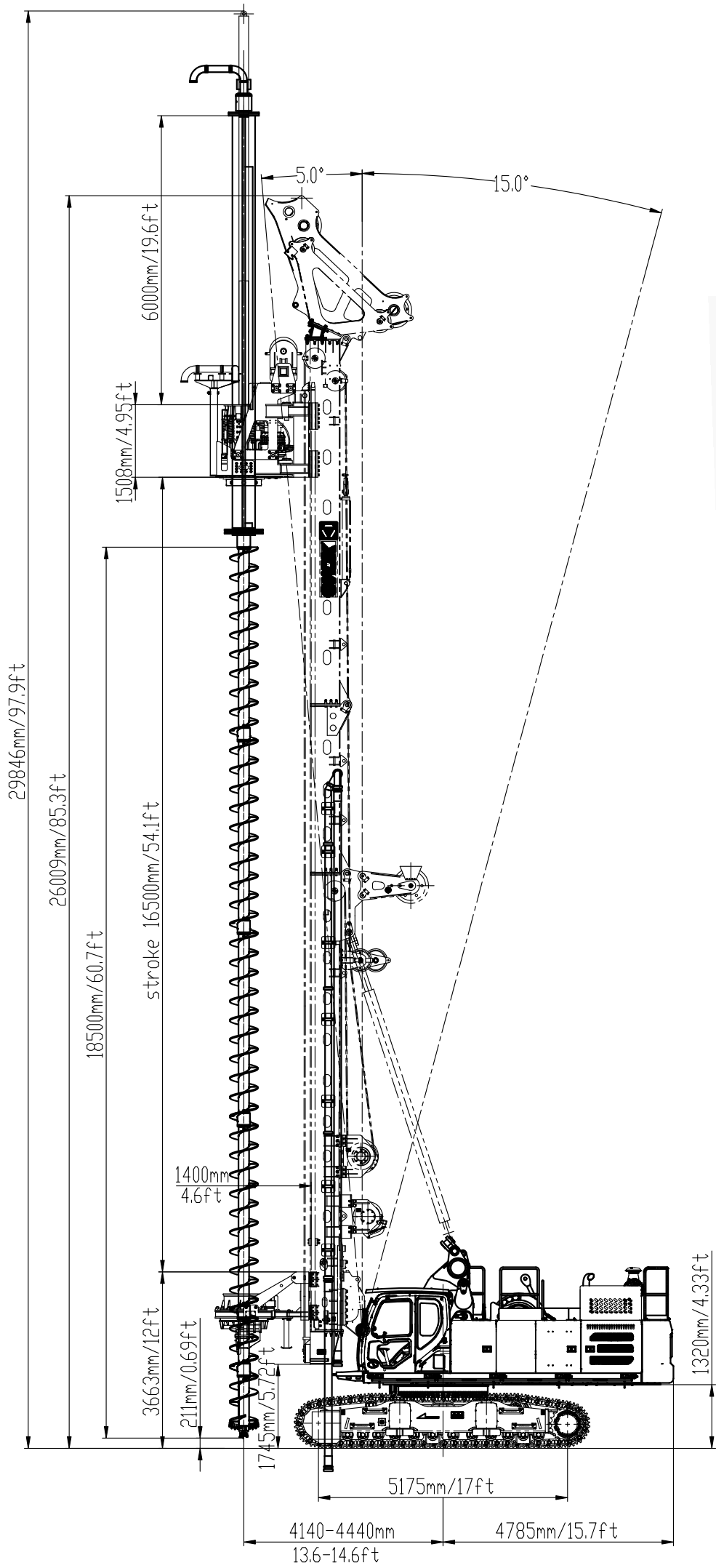

In CFA mode with 6m extension		Without auger cleaner	With auger cleaner	Max. drilling diameter
		55.8+19.6'	52.5+19.6'	2.6'
		17m+6m	16m+6m	Φ800mm

XC-95F Specifications

1. Mast I: 10.8t, See the figure below for the dimension

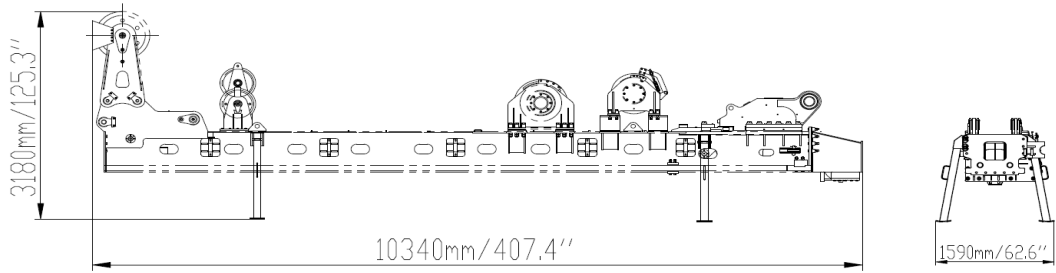

2. Inclination cylinders: 1.6t*2=3.2t, $\Phi 210$ -6100mm, 2 pcs

3. Mast II: 1.6t. See the figure below for the dimension.

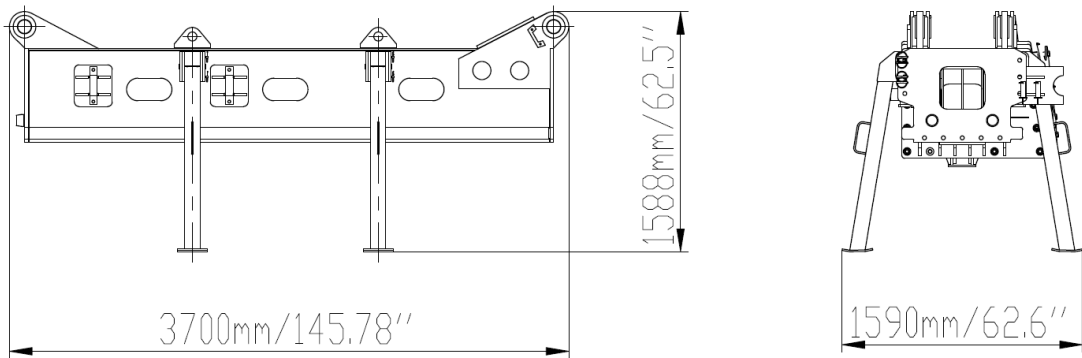

4. Mast III: 4.3t. See the figure below for the dimension.

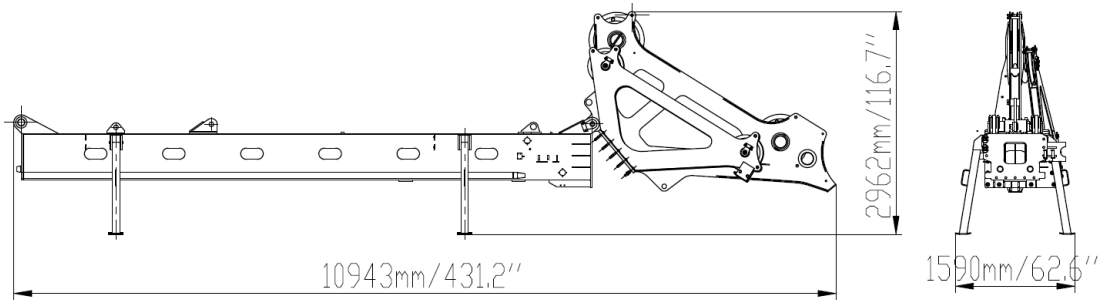

5. Counterweight: 9t. See the figure below for the dimension of counterweight.

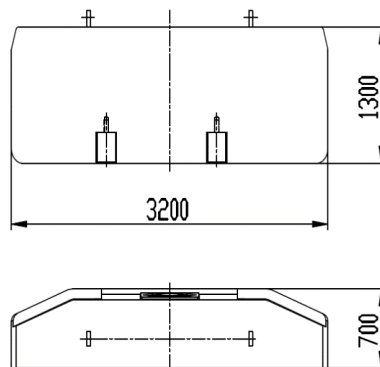

XC-95F Specifications

6. Weight of Rotary drive assembly: 10t; See the figure below for overall dimension.

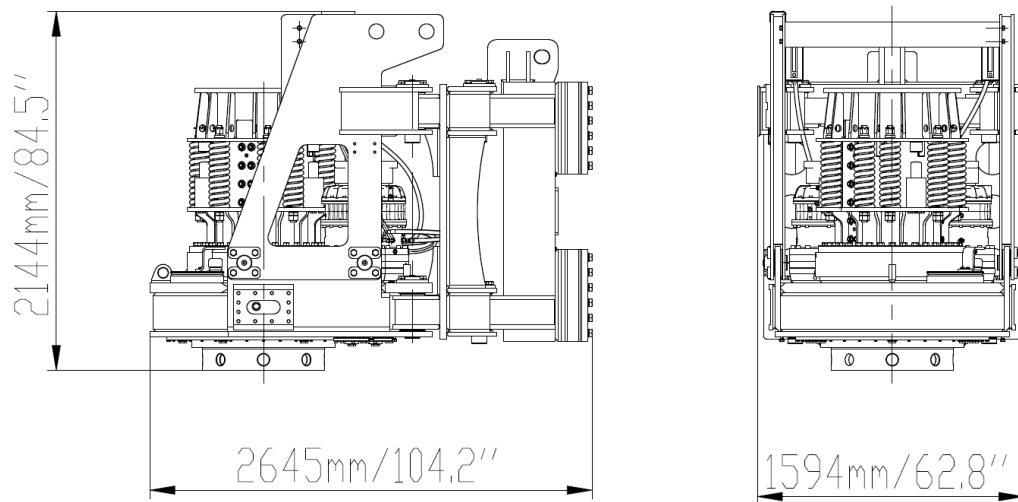

7. Disassembled rig: 54.5t; overall dimension is shown in the figure below; transportation width: 3,500mm

